



DUAL/SINGLE OUTPUTS BOOSTER CHARGER

USER MANUAL

DM Series



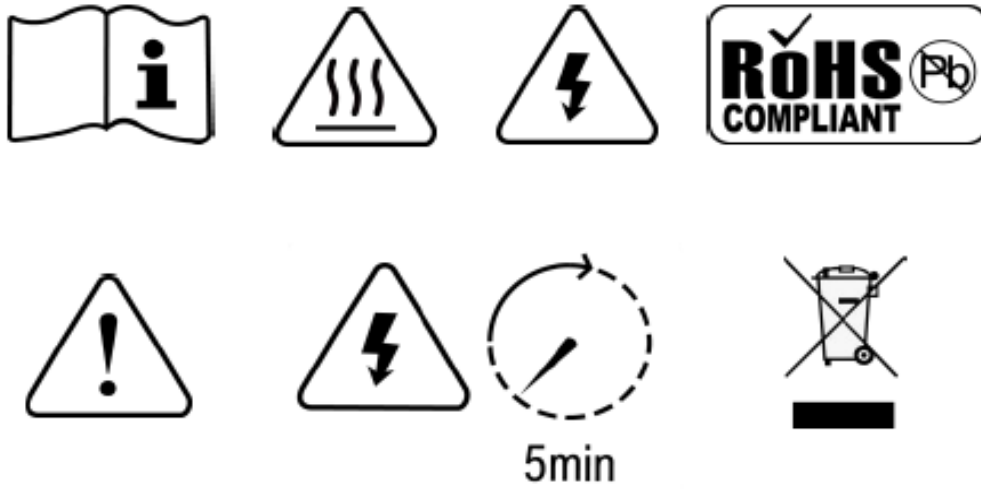

WARNING: HIGH VOLTAGE INSIDE

CAUTION: THE DC FUSE MUST HAVE BEEN TURNED OFF BEFORE SERVICING

MADE IN CHINA

Disclaimer

Unless specially agreed in writing, TBB POWER(XIAMEN) CO.,LTD

- Takes no warranty as to the accuracy, sufficiency of suitability of any technical or other information provided in this manual or other documentation.
- Assumes no responsibility or liability for loss or damage, whether direct, indirect, consequential or incidental, which might arise out of the use of such information.
- Offers standard warranty with its products, taking no responsibility for direct or indirect loss due to equipment failure.

About this Manual

This manual describes the features of the dual/single outputs booster charger, and provides the procedure of installations. This manual is for anyone intending to install our product.

General Instruction

Thanks for choosing our products and this manual is suitable for dual/single outputs booster charger.

This chapter contains important safety and operation instructions. Read and keep this User Guide well for later reference.

This system needs to be installed by professionals with enough knowledge of electrical system. Please pay attention to the following points prior to installation:

- 1) Please check the input voltage is same to the nominal input voltage of this unit.
- 2) Upon connection with Alternator, battery and fridge/load, please double confirm the polarity.
- 3) Please use the shortest possible cable to connect and ensure the secure connection.
- 4) While connecting, please secure the connection and avoid short circuit between positive terminal and negative terminal.
- 5) The unit will have high voltage inside. Only authorized electrician can open the case.
- 6) The unit WAS NOT designed to use in any life retaining equipment.

Contents

1. General Safety Instruction.....	1
2. Introduction	2
2.1 General introduction.....	2
2.2 Topology	3
2.3 Booster mode logic	4
2.4 TBB Premium II charging algorithm.....	4
2.5 Battery temperature compensation	5
2.6 Back-charging function.....	5
2.7 De-rate curve against temperature increase	6
3. Structure and dimension	8
3.1 Exterior and dimension	8
3.2 Connectors and terminals	9
3.3 LED indication.....	10
4. Installation.....	12
4.1 Material checking	12
4.2 Prepare harness	12
4.3 Proper installation location	13
4.4 Installation space	13
4.5 Mounting holes.....	14
4.6 Auxiliarybattery type and fridge load work mode setting.....	14
4.7 Cable connection	16
5. FAQ	18
6. Specification	19

1. General Safety Instruction

Safety Instruction

As dangerous voltage and high temperature exist within the charge controller, only qualified and authorized maintenance personnel are permitted to open and repair it.

This manual contains information concerning the installation and operation of the charge controller. All relevant parts of the manual should be read prior to commencing the installation. Please follow the local stipulation meantime.

Any operation against safety requirement or against design, manufacture, safety standard, and are out of the manufacturer warranty.

General Precaution

- Do not expose to rain, snow or liquids of any type, it is designed for indoor use.
- To avoid fire and electric shock, make sure all cables selected with right gauge and being connected well. Smaller diameter and broken cable are not allowed to use.
- Please do not put any inflammable goods near to charge controller.
- Never place unit directly above batteries, gases from a battery will corrode and damage the charge controller.
- Do not place battery over charge controller.

Precaution regarding battery operation

- Use plenty of fresh water to clean in case battery acid contacts skin, clothing, or eyes and consult with doctor as soon as possible.
- The battery may generate flammable gas during charging. Never smoke or allow a spark or flame in vicinity of a battery.
- Do not put the metal tool on the battery, spark and short circuit might lead to explosion.
- Remove all personal metal items such as rings, bracelets, necklaces, and watches while working with batteries. Batteries can cause short-circuit current high enough to make metal melt, and could cause severe burns.

2. Introduction

2.1 General introduction

TBB's DM series charger is an in-vehicle charging solution which specified designed for on-board application such as RV, Marine, Utility Vehicle, Truck etc.

Dual outputs DMT1250S/DMT1265S comes with a brilliant feature of dual outputs: one is for auxiliary battery charging with charge current up to 30A/45A, and the other one is dedicated to power a DC load (Typically a DC fridge) with current up to 20A. When vehicle engine is running, DMT will draw power from engine to charge battery as well as to power DC load; when vehicle engine is turned off, DMT will draw power from auxiliary battery to power DC load. So that connected DC load could be powered always either by engine or auxiliary battery.

Single output DM1220S, DM1230S, DM1245S and DM1260S are the booster charger only with charge current up to 20A, 30A, 45A and 60A respectively for 12V system.

All DM and DMT chargers are Euro-6 engine compatible, which is able to charge auxiliary battery properly and fully with much wider variable voltage output from engine.

Features

- Dual outputs, separate circuits for charging battery and powering DC load (DMT Models);
- Non-isolation design with max efficiency 96%;
- Euro-6 engine (Smart alternator) compatible;
- TBB Premium II multiple stages charging algorithm;
- Multiple battery chemical for optional including lithium battery;
- Built-in automatic temperature compensated charging;
- Plug and Play for easy installation;
- Natural cooling without fan;
- Supports RS485 communication;
- Protection against input/output over voltage, output over current, output short circuit, internal over temperature, battery over temperature, battery low temperature protect for LFP etc.
- Back-charging function.

2.2 Topology

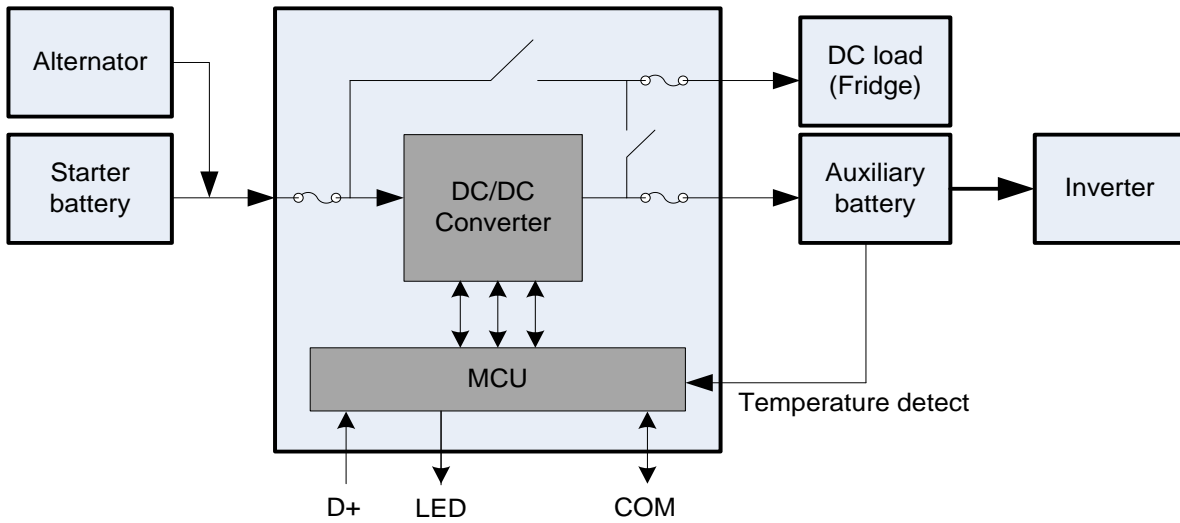

Figure 2-1 Topology of DMT models

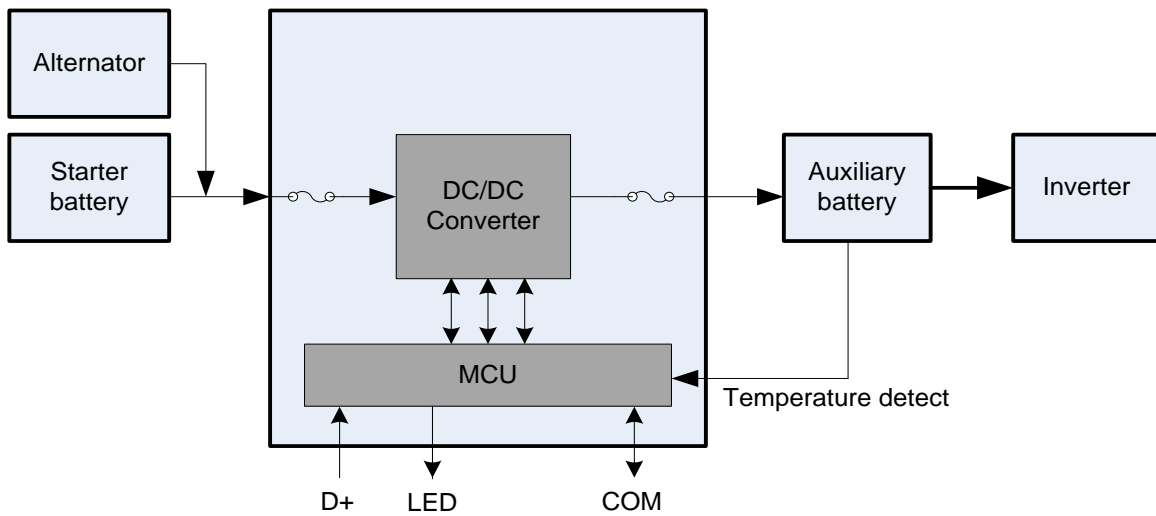

Figure 2-2 Topology of DM models

Thanks to its non-isolation design, the charging efficiency of DM/DMT is up to 96%.

When both alternator and auxiliary battery are well connected, DMT will automatically judge if engine is turning on by detecting D+ signal or sensing alternator output voltage, to decide charge battery and power DC load by alternator, or power DC load by auxiliary battery.

All models support communication of RS485.

2.3 Booster mode logic

Table2-1 Charging logic for 12V system

ACC+/D+	Term	Configuration	
		Starter battery voltage	
		Default	Range
With ACC+/D+ connected	D+/ACC+ AND voltage meets the threshold	$\geq 13.2V$	12~14.5V
Without ACC+/D+ connected	voltage meets the threshold	$\geq 13.2V$	12~14.5V

Table2-2 Stop charging logic for 12V system

ACC+/D+	Term	Configuration	
		Starter battery voltage	
		Default	Range
With ACC+/D+ connected	no D+/ACC+ OR voltage meets the threshold	$< 12.8V$	11.6~13.5V
Without ACC+/D+ connected	voltage meets the threshold	$< 12.8V$	11.6~13.5V

Remark: All above threshold voltage can be configured by Program Tool RapNEMO.

2.4 TBB Premium II charging algorithm

Fitted with TBB Premium II charging algorithm, DM/DMT Models is able to charge auxiliary battery quickly and fully. Microprocessor controlled charging algorithm with variable absorption charging timer to guarantee the optimal charging for batteries of different discharged states.

Float charging program guarantee your battery get proper maintenance in case of long time connected.

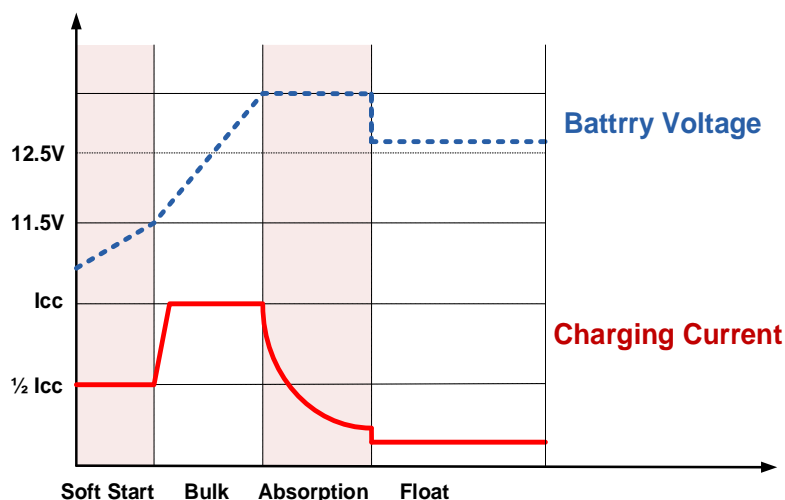

Figure 2-3 TBB Premium II Charging Algorithm

2.5 Battery temperature compensation

Battery temperature is a key factor in correct charging, the charging formula must be adjusted (automatically and in real time) according to the actual battery temperature to ensure that battery are fully charged but not overcharged or undercharged. All charging voltages recommended by battery manufacture are in fact only applied at 20°C-25°C.

The BTS (Battery Temperature Sensor) supplied with DM/DMT measures the temperature of battery and automatically makes adjustments at real time to properly charge your batteries at the default compensation rate of – 3mv/°C/cell.

In case of BTS was not present, the charger will use 25°C as default setting.



Figure 2-4 Battery Temperature Sensor(BTS)

2.6 Back-charging function



It's required to connect D+ cable or ACC signal to enable back-charging function.

All standard models comes with back-charging function, which allows DMT/DM draws power from auxiliary battery to charge starter battery (charge current is from 0-3A). With back-charging function, it will prevent starter battery to get flat which fails to start engine.

Table2-3 Back-charging logic for 12V system

ACC/D+	Term	Starter battery voltage	Value Configuration	
			Auxiliary battery voltage	
			Default	Range
With ACC+/D+ connected	No ACC+/D+ is detected and voltage meet the threshold	≤12.4V	≥12.2V	12.2~14.5V
Without ACC+/D+ connected	without this function			

Table2-4 Stop back-charging logic for 12V system

ACC/D+	Term	Starter battery voltage	Value Configuration	
			Auxiliary battery voltage	
			Default	Range
With ACC/D+ connected,	ACC+/D+ is detected OR voltage meet the threshold	$\geq 12.8V$	$\leq 12V$	12~14.3V
Without ACC+/D+ connected	without this function			

Remarks:

1. Auxiliary battery voltage should be 0.5V higher than starter battery voltage.
2. All above threshold voltage can be configured by Program Tool RapNEMO.
3. Back charging function is only available upon D+/ACC+ connected.

2.7 De-rate curve against temperature increase

DM/DMT monitors the internal temperature to decide output power. It will de-rate its output power against temperature increasing. Below is a curve to reflect the change of output power with temperature increase.

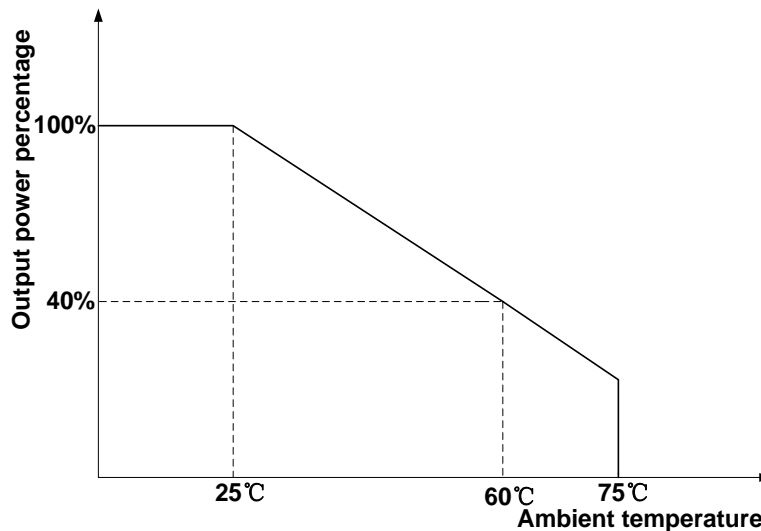

Figure 2-5 De-rate curve against temperature increase

2.8 Forced D+ mode

The forced D+ mode is specified designed for special chassis (For example EURO 6D TEMP) which with lower engine output voltage. Below is difference of Normal D+ mode and Forced D+ mode.

Table2-5 Normal D+ and Forced D+ mode description

Mode	Start working condition	Stop working condition
Normal D+	D+ signal is detected and booster input voltage must be greater than 12.2Vdc (This voltage could be set)	No D+ signal is detected or booster input voltage is less than 11.6Vdc (This voltage could be set)
Forced D+	D+ signal is detected	No D+ signal is detected

As description in above Table, Forced D+ mode is enable/disable by with/without D+ signal only; but has nothing to do with booster input voltage. Forced D+ working mode can be configured by Program Tool RapNEMO.

3. Structure and dimension

3.1 Exterior and dimension



Figure 3-1 Product front view

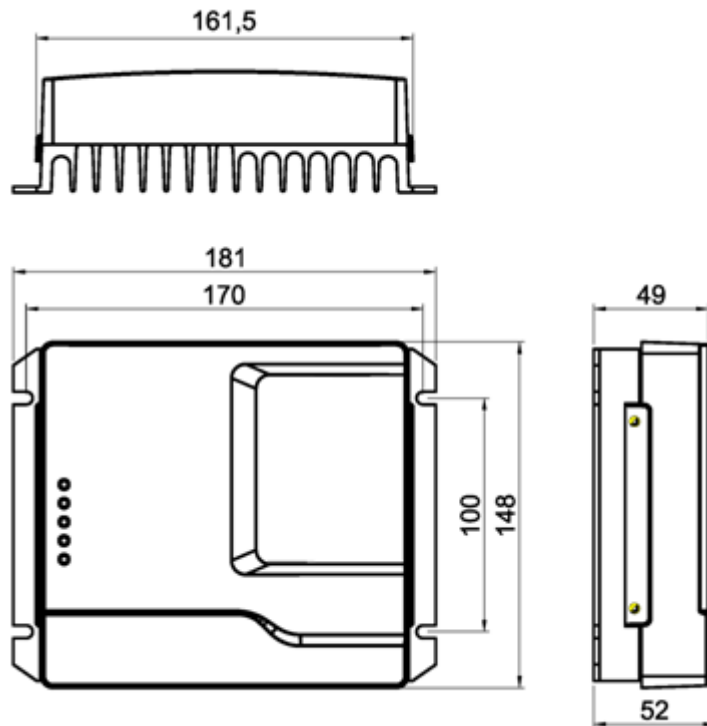

DMT1250S/DM1220S/DM1230S/DM1245S

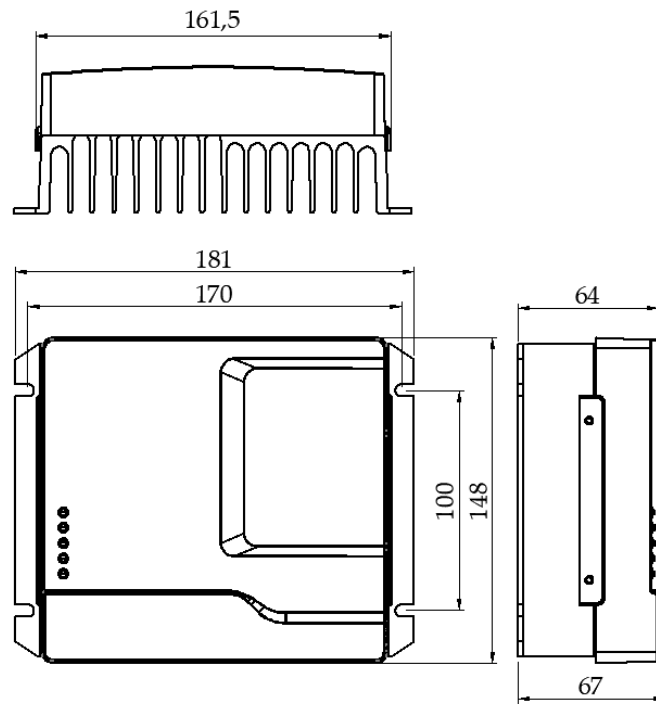

DM1260S/DMT1265S

Figure 3-2 Product dimension

3.2 Connectors and terminals

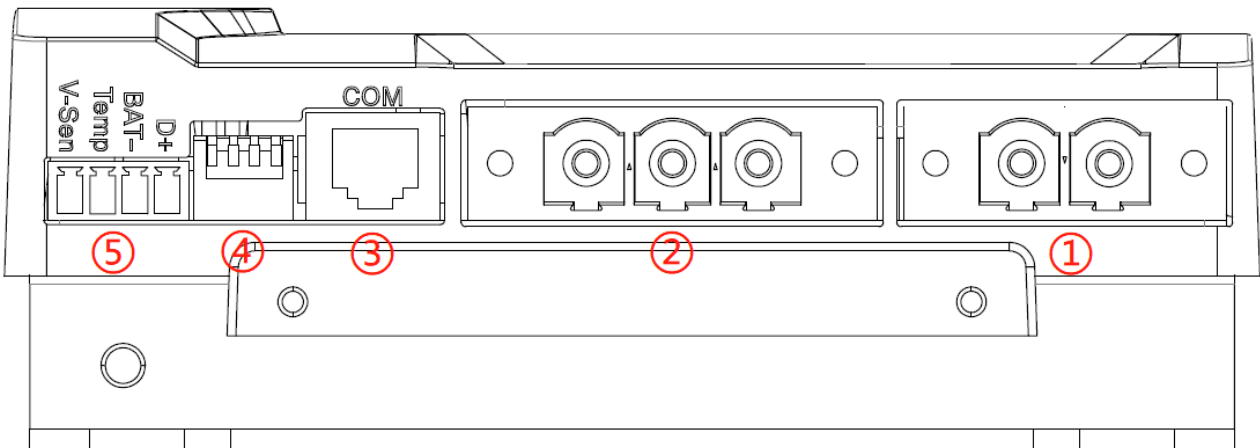

Figure 3-3 Connectors and terminals

Table 3-1 Connectors and terminals definition

No.	Print	Definition	Remarks
①	Alternator	Connects to positive of Alternator	Or connects to positive of starter battery
	BAT-	Connects to negative of Alternator	Or connects to negative of starter battery
②	Fridge/Load	Connects to positive of DC load (Fridge)	No available for DM Models
	AUX BAT	Connects to positive of auxiliary battery	
	BAT-	Connects to negative of DC load (Fridge) and negative of auxiliary battery	
③	COM	For communication of RS485	Pin definition can be found as below Table 3-2
④	1	Dip switch for working mode setting or address setting	Details of setting can be found as Chapter 4.6
	2		
	3	Dip switch for battery type setting	
	4		
⑤	D+	Connects to D+ or ACC signal at smart alternator	
	BAT-	Connects to BTS' black cable	For battery temperature sensing
	Temp	Connects to BTS' white cable	
	V-Sen		Reserved

Table 3-2 COM communication interface pin definition

No.	Definition	Description
1	N/A	N/A
2	N/A	N/A
3	RS485-A	RS485-A communication pin
4	N/A	N/A
5	N/A	N/A
6	RS485-B	RS485-B communication pin
7	+12V	Display screen power supply +12V
8	GND	Display screen power GND

3.3 LED indication

Table 3-3 LED indication

No.	Print	Color	Status	Description
1	Power	Green	ON	Power on
			OFF	Shutdown or Sleep Mode
2	Fridge/Load (No available for DM Models)	Green	ON	Fridge/Load working
			Fast flashing	Fridge/Load is over-temperature; or output to Fridge/Load is over-current
			OFF	Fridge/Load no working
3	Alternator	Green	ON	Starter battery voltage in the range
			Fast flashing	Starter battery voltage high
			Slow flashing	Auxiliary battery charges to starter battery
			OFF	Starter battery voltage low
4	Charge	Green	ON	Charging battery at bulk or absorption stage
			Slow flashing	Charging battery at float stage
			OFF	No charging to auxiliary battery
5	Fault	Red	ON	1. Charger over temperature 2. Starter battery voltage high 3. Output to auxiliary battery short circuit
			Fast flashing	Fridge/Load over temperature or over current (For DMT Models)
			OFF	No fault

Note:

Fast flashing: LED flashing on for 0.25s and off for 0.25s

Slow flashing: LED flashing on for 0.25s and off for 1.75s

4. Installation

4.1 Material checking

Before installation, please open the box to check if the product is broken or it's the right item you purchased. If you have any question, please don't remove the package and contact us in first time.



Please check the item with the list attached in the box.

4.2 Prepare harness

The output and input cable has to be fabricated at customer end. The suggested cable specification and counter connector could be found as below Table 4-1.

Table 4-1 Cable fabrication and counter connector

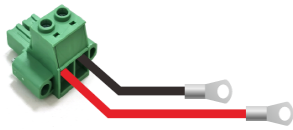
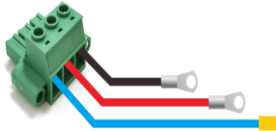
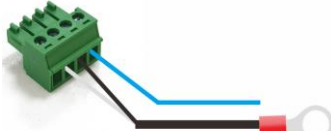
Connector at DMT	Print	Counter connector	Cable specification			
			Gauge	Length	Color	Terminal
Input connector port	Alternator		10~16mm ²	<3m	Red	M8 terminal
	BAT-		10~16mm ²	<3m	Black	M8 terminal
Output connector port	Fridge Load		4~6mm ²	<3m	Blue	(No available for DM models)
	AUX BAT		6~16mm ²	<3m	Red	M8 terminal
	BAT-		10~16mm ²	<3m	Black	M8 terminal
Signal connector port	D+		0.3mm ²	--	Blue	--
	BAT-		0.3mm ²	2m	Black	M8 terminal
	Temp		0.3mm ²	2m	White	M8 terminal
	V-Sen		No available			

4.3 Proper installation location

- DM/DMT are designed with IP20, the installation location should be indoor.
- The temperature at the house and heat sink of the charger will be as high as 60°C during its working. So please have it installed at a location hard to touch.
- Please have the installation stay away from inflammable and explosive goods.
- Please have the installation stay away from kids.
- Don't install the charger based on inflammable material.
- Please insure the mounting surface is solid enough for installation.
- Wall-mounted installation is recommended to help the product heat dissipation.



Please never install the charger into a seal enclosure with battery.

4.4 Installation space

It's required to leave space at installation for ventilation. The dimension for ventilation is defined as below.

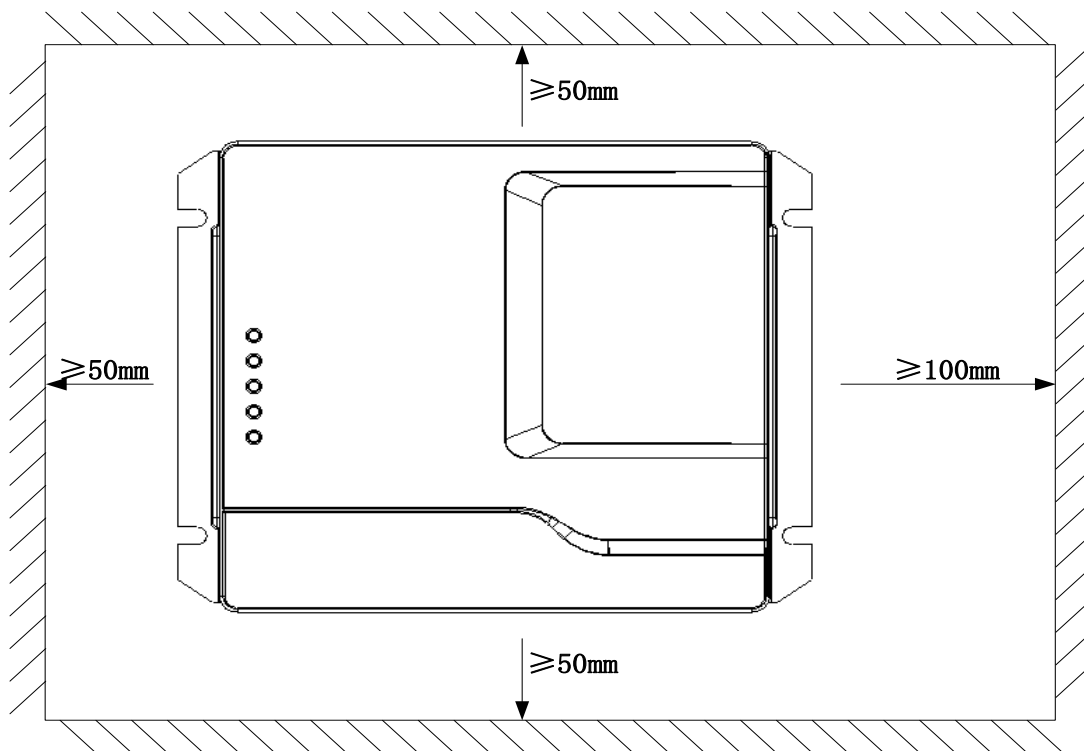

Figure 4-1 The required dimension for ventilation

4.5 Mounting holes

Find a appropriate mounting surface, drill mounting holes as dimension shown in below picture.

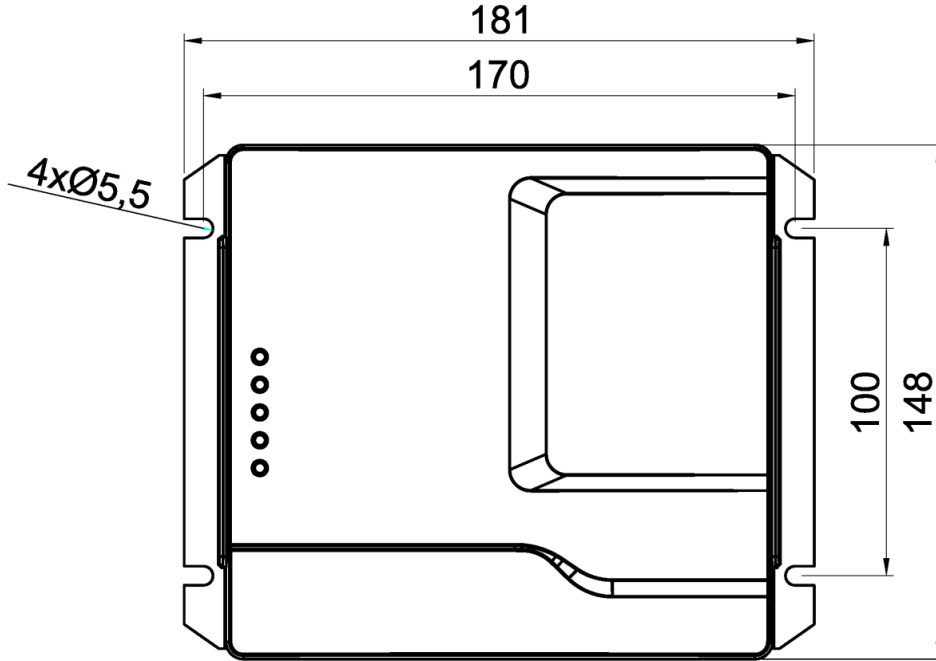



Figure 4-2 Drill holes for mounting



Please have the charger installed with auxiliary battery as close as possible to reduce voltage drop on cable.

4.6 Auxiliary battery type and fridge load work mode setting

Table 4-2 Dip switch setting for battery type

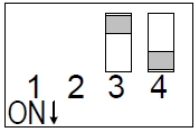
Dip switch for battery type setting			Battery type	12V battery	
Pin 3	Pin 4	Illustration		Absorption charging voltage	Float charging voltage
OFF	OFF		AGM (Default setting)	14.4V	13.5V
OFF	ON		GEL	14.1V	13.7V

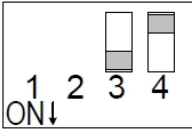
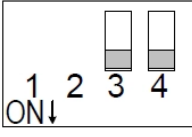
ON	OFF		LFP	14.2V	14.0V
ON	ON		WET	14.7V	13.5V

The voltage of auxiliary battery must be above 2V if the battery type isn't lithium type, or the charger will not charge to auxiliary battery. If the auxiliary battery is lithium type and the voltage is below 2V, the charger works on 'wake up' mode with a constant voltage output until the output current over 3A and then the charger turns into the battery charging mode.

Table 4-3 Dip switch setting for working mode (For DMT Models)

Dip switch for working mode			Working mode	Description
Pin 1	Pin 2	Illustration		
OFF	Either ON or OFF		No power to DC load (Fridge)	DMT models will not power DC load (Fridge) under this mode.
ON	OFF		Power DC load (Fridge) only upon driving	Under this mode: -DMT models will draw power from alternator to power DC load (Fridge) when engine is ON. -DMT models will stop powering DC load (Fridge) when engine is OFF.
ON	ON		Power DC load (Fridge) always (Default setting)	Under this mode: -DMT models will draw power from alternator to power DC load (Fridge) when engine is ON. -DMT models will draw power from auxiliary battery to power DC load (Fridge) when engine is OFF.

Table 4-4 Dip switch setting for communication address Setting (For DM Models)

Dip switch for communication address Setting			Communication address
Pin 1	Pin 2	Illustration	
OFF	OFF		1

OFF	ON		2
ON	OFF		3
ON	ON		4

Note:
Auxiliary battery type and DC load work mode can be configured by program tool RapNEMO.

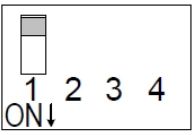
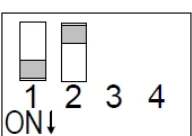
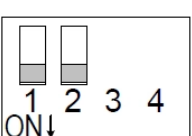
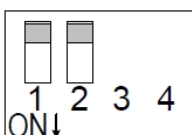
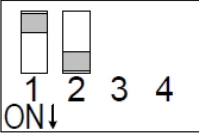
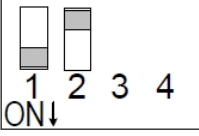
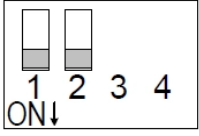
4.7 Cable connection

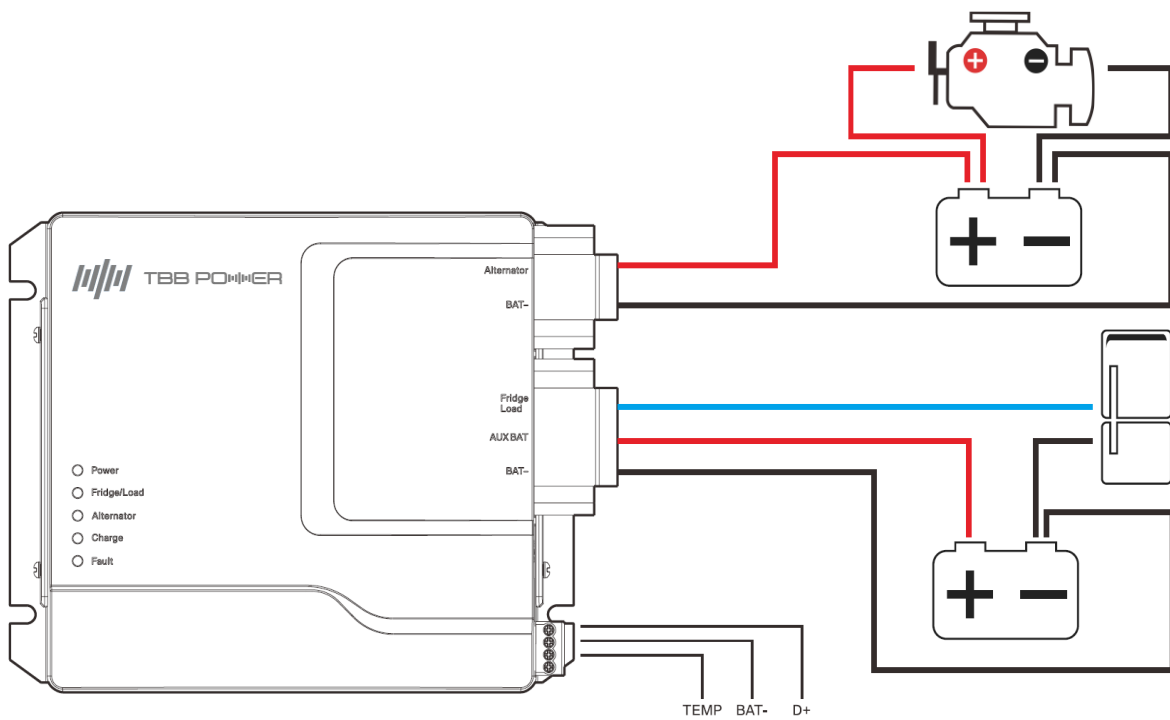

Figure 4-3 Connection diagram

Step 1: Prepare proper cables to connect with positive and negative terminals of starter battery; and fix them into counter part of input connector which also provided by TBB.

Step 2: Prepare proper cables to connect with positive and negative terminals of auxiliary battery, as well as positive and negative connector of DC load (Fridge); and fix them into counter part of output connector which also provided by TBB.

**Remarks: For DM models, not necessary to prepare connectors for DC load.
Rated torque: 1.2Nm.**

Step 3: Prepare proper signal cable to connect with D+ at smart alternator; and fix battery temperature sensor cables into counter part of signal connector which also provided by TBB.

Remarks: When the battery type is set to LFP, there is no need to install a battery temperature sensor.

Step 4: Connects above cable in Step 1 to positive and negative terminals of starter battery; then plug counterpart into input connector on the charger respectively.

Step 5: Connects to above cables in Step 2 to positive & negative terminals of auxiliary battery and positive of DC load(Fridge); then plug counterpart into output connector on the charger.

Step 6: Connects above signal cable in Step 3 to alternator D+ and positive terminal of auxiliary battery; then plug counterpart into signal connector on the charger respectively.

Remarks: The negative cable of DC load (Fridge) will be connected to negative terminal of auxiliary battery directly or chassis.



It is strictly forbidden to use the device with other voltages or AC power, otherwise it will cause short circuit, fire and other accidents, putting people and the charger at risk.



Please make sure there is not reverse polarity connection anywhere. Please also check if connection is stable enough. Any damage caused by improper connection will be out of TBB's warranty.

5. FAQ

No.	Issue	Analysis and countermeasure
1	Indicator of Alternator flashing, and indicator of Fault ON	1. Please check if voltage of alternator or voltage of starter battery is higher than 16.0V; if yes, please wait for the voltage dropped to 15.0V. If voltage of them is in the normal range while indicator is still flashing, please contact TBB for further advice.
2	Indicator of Fridge/Load flashing, and indicator of Fault ON (For DMT Models)	1. Please check if ambient temperature is over-temperature; If yes, please wait to the temperature is dropped to working range. 2. Please check if required current of fridge is greater than 21A; if yes, please make sure the required current is equal or less than 20A. 3. Please contact TBB for further advice if temperature and current are good while still have indicator flashing.
3	Indicator of Fault flashing, and indicator of Fridge/Load either ON or OFF	1. Please check if auxiliary battery is greater than 55°C; if yes, please have battery temperature dropped to 45°C. 2. Please contact TBB for further advice if temperature is good while still have the issue.
4	Indicator of Fault ON, and indicator of Alternator either ON or OFF	1. DMT is over temperature, please have it dropped to working temperature range. 2. Please check if output to auxiliary battery short circuit. Please contact TBB for further advice if no above phenomenon but still have indicator issue.

6. Specification

Model NO.	DMT		DM			
	1250S	1265S	1220S	1230S	1245S	1260S
Electrical						
Alternator input voltage range (Default setting)	13.2~16VDC					
Automatic activation D+	Yes					
Absorption charge voltage (Default Setting)	14.6VDC					
Float charge voltage (Default Setting)	13.5VDC					
Charge current(max)	30A	45A	20A	30A	45A	60A
Load bypass current(max)	20A		N/A			
Total current of load and charging(max)	50A	65A	20A	30A	45A	60A
Maximum charging efficiency	96%					
Maximum load bypass efficiency	99%		N/A			
Temperature compensation	Default Setting: -3mV/°C/cell					
Charge algorithm	TBB premium II multi stage					
Protection	Battery charger over temperature; Battery over temperature; Over load; Short circuit					
Back-charging function	Standard					
Communication	RS485, RJ45 connector					
Storage temperature	-40°C~70°C					
Operating temperature	-40°C~70°C					
Enclosure						
Battery Connection	Cable with connector					
Protection category	IP20					
Weight	1.0kg	1.2kg	1.0kg		1.2kg	
Dimensions (h*w*d)	181*148* 52mm	181*148* 67mm	181*148*52mm			181*148* 67mm
Standards						
Emission	ECE 10R-06, EN61000-6-1, EN61000-6-3					

TBB POWER (XIAMEN) CO.,LTD

 sales@tbbpower.com

 www.tbbpowermobile.com

 +86-592-5212299

 +86-592-5796070