



www.photonicuniverse.com

+44 (0) 203 150 11 11

DC to DC Battery Charger

DC1212, DC1224, DC2424 and DC2412 series

INSTRUCTION MANUAL

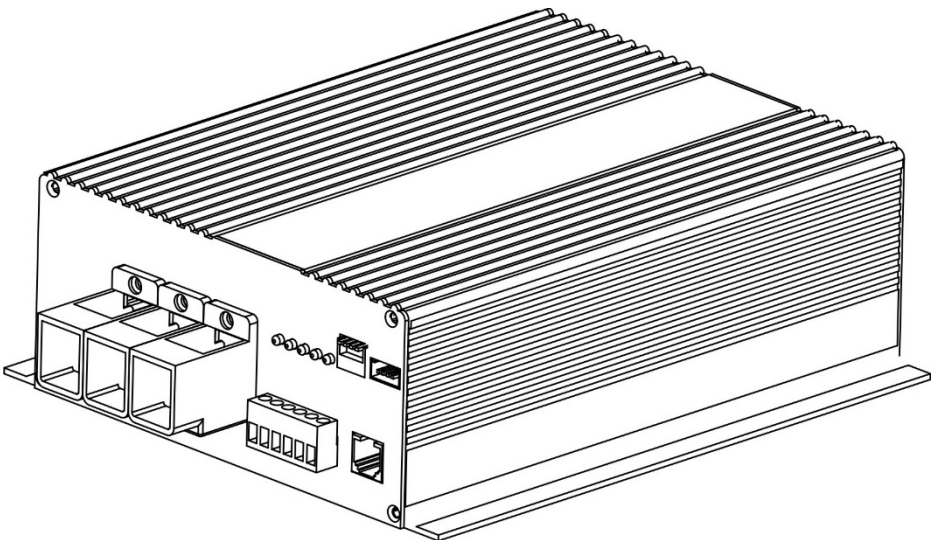

Charger models

12V to 12V

Model	Input voltage -> output voltage	DC-DC charger current
DC1212-30	12V → 12V	12V/30A
DC1212-60	12V → 12V	12V/60A

12V to 24V

DC1224-25	12V → 24V	24V/25A
-----------	-----------	---------

24V to 24V

DC2424-50	24V → 24V	24V/50A
-----------	-----------	---------

24V to 12V

DC2412-60	24V → 12V	12V/60A
-----------	-----------	---------

Overview

This Photonic Universe DC-DC battery charger is fully automatic and ideal for leisure vehicles, commercial and special purpose vehicles, boats, and any other systems with multiple batteries or power sources. The charger operates using an adjustable three-stage charging programme and is suitable for lead acid, AGM, GEL, LiFePO4 and Lithium-ion (NCM) batteries. The product features high frequency switching and buck-boost power conversion technology for reliable, consistent performance.

The D+ terminal of the charger activates the charging function automatically when the vehicle alternator starts, avoiding battery discharge when it stops. A range of protection functions enables the charger to automatically disconnect the target (OUT) battery from the source (IN) battery under extreme conditions, such as in case of overheating, overvoltage, short circuits, and over-currents. Backflow (from OUT to IN) is also prevented so the charge will not flow in the reverse direction.

The charger includes ports for a remote meter or a Bluetooth dongle (both sold separately), allowing data to be viewed on an LCD display or through a mobile phone app when connected.

An optional external temperature sensor (sold separately) can be connected to the charger for automatic adjustment of the charging voltages depending on the ambient temperature (lead-acid batteries only), keeping the charging programme to optimal voltages at very low or high temperatures.

The charger also features an automatic wake-up function for lithium batteries. When the Battery Management System (BMS) of a lithium battery goes into the protection mode, the charger can automatically activate the BMS and continue charging the lithium battery.

Installation

Install the battery charger as close to the target (OUT) battery as possible and keep the surrounding area clean, tidy, and well ventilated. This space should be moisture-proof, water-proof, and corrosion proof. Leave at least 10 cm of space around the charger for proper airflow.

Note: before connecting and using the charger, please choose the type of target battery (lead-acid, GEL, AGM, LiFePO4, Lithium-ion (NCM)) by setting DIP switches 2-4. If you intend to charge a lithium battery in cold temperatures, ensure to verify if your battery can be charged at temperatures below 0°C, and adjust DIP switch 1 as needed. For more information, refer to the DIP switches section in this manual.

Connection diagrams

Use as short cables as possible, especially between the charger and the target battery. The recommended cable cross-section for “+” and “-” power cables is 1 mm² cross-section for every 3A of maximum charging current. Always connect the cables to the charger terminals first before connecting them to the battery terminals, to ensure you are not working with live cables. When connecting the cables to the battery terminals, ensure the positive and negative poles are not reversed or short-circuited.

The fuses need to be located within 15 cm from the terminals of the batteries. Choose the rating of the fuses according to the maximum charging current.

Connection diagram for DC1212-30 & DC1212-60:

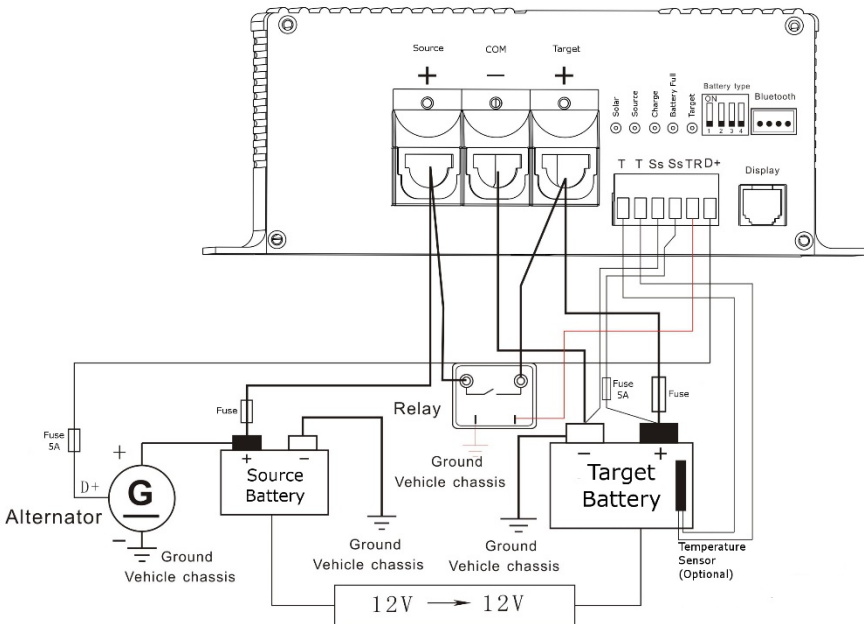

Connection diagram for DC1224-25, DC2412-60 & DC2424-50:

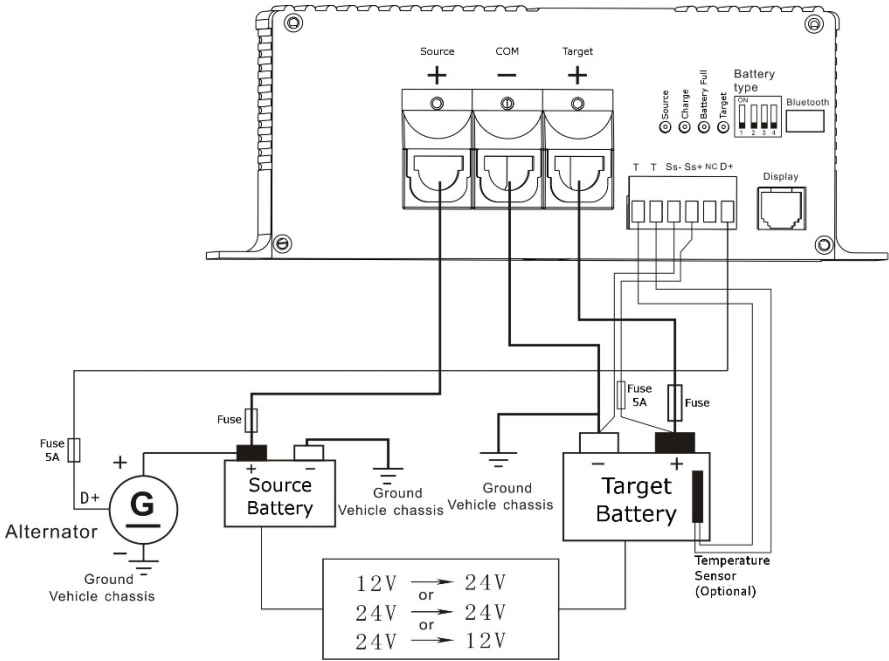

IMPORTANT! The charger requires a D+ signal to operate. If there is no signal applied to the D+ terminal, the charger will not turn on. If your system doesn't have a D+ signal, the D+ terminal can be wired directly to the positive terminal of the source battery to turn on the charger.

Green terminals

The charger features a pluggable terminal block of 6 green terminals. In a place with limited installation space, the terminal block can be unplugged for connection or disconnection of the wires and then re-inserted. The size of the cable for this terminal block is 0.75mm² and the stripping length is about 6mm. Description of the terminal contacts is provided below.

“T T”: these are the terminals for connecting an optional temperature sensor for measuring the temperature of the target battery.

If you install a temperature sensor in your system, please ensure that it is not affected by any heat source. Fix it on the case of the target battery or connect it to the negative terminal of the battery.

A temperature sensor is highly recommended for lead acid batteries in case if the ambient temperatures vary substantially from the baseline temperature of 25°C. The sensor performs two main functions:

- Charging voltage adjustment. The charging voltage for the target battery is compensated up or down depending on the ambient temperature to regulate the speed of chemical reaction inside the battery. The voltage will increase in the winter and decrease in the summer at the rate of 18mV (12V battery) / 36mV (24V battery) for each degree Celsius away from the reference temperature 25°C.
- Battery protection. When the temperature is lower than -20°C or higher than 50°C, the charger limits the maximum charging current.

The charger can identify whether the temperature sensor is connected or not, or if it is damaged, short-circuited, or when an abnormal temperature is measured. In such case, the charger will automatically set the charging programme to the default temperature 25°C.

Note: there is no temperature compensation for lithium batteries.

“Ss-, Ss+”: these are the terminals used for connecting optional battery cables directly to battery terminals for precise voltage measurement of the target battery. This will provide the charger with accurate readings of the voltage of the battery to ensure they are not affected by the voltage drop in heavy duty “+” and “-” charging cables. The voltage reading cables must be fused.

If these cables are not connected or the connection is interrupted, the charger will measure the voltage across the target battery terminals using the regular heavy duty charging cables connected to “+” and “-” terminals of the charger.

If multiple batteries are being used in parallel, connect Ss- to the negative terminal of the first battery, and connect Ss+ to the positive terminal of the last battery.

“TR”: relay signal terminal. If a high starting current is required by some electrical loads connected to the target battery (fridge, air conditioner, inverter etc), and the target battery cannot start them on its own and its voltage drops below 12.5V, the “TR” terminal can provide a 12V + signal which can close an optional relay (purchased separately) installed between the “+” of the source battery and the “+” of the target battery. This will effectively connect the two batteries directly to each other allowing the source battery to assist the target battery in starting high current electrical loads.

Note: only 12V to 12V chargers (DC1212-30 and DC1212-60) have this “TR” terminal and the relay signal function.

“D+”: this is the terminal for connecting a “D+” signal (12V + / 24V +) from the alternator, if the charger is used in a vehicle and the source battery (IN) is the vehicle’s starter battery. This terminal controls the ON / OFF function of the charger. The charger will only operate at times when the alternator sends a “D+” signal to this “D+” terminal i.e. at times when the alternator is working. The input voltage range for “D+” signal is 8V – 16V for chargers designed for 12V source batteries and 16V – 32V for chargers designed for 24V source batteries.

Alternatively, another connection option in a vehicle where the starter battery is used as a source battery, is to connect the “D+” terminal of the charger to the 12V + / 24V + signal from the

ignition of the vehicle. In such case, if the ignition is ON, the charger will be ON and if the ignition is OFF, the charger will be OFF.

In a system without an alternator, this “D+” terminal should be connected to the terminal of the source battery to enable the charger to turn on. **The charger will not operate if “D+” terminal is not connected.** It is also possible to fit a suitable ON/OFF switch between the “D+” terminal and the positive terminal of the source battery to control the ON / OFF function of the charger.

Lithium battery 0°C charging function

DIP switch 1 is used to select whether the lithium battery 0 °C charging protection is turned On or Off.

Selecting “ON” means that the protection is enabled, and the charger will stop charging a lithium battery when the temperature is below 0 °C. Selecting “OFF” means that the protection is disabled, and the charger will continue charging the battery even in cold temperatures below 0°C. The exact actions of the charger depending on the temperature are as follows:

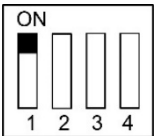
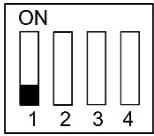

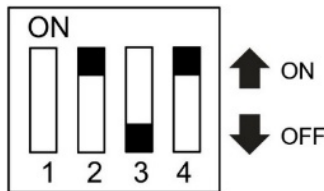



Switch	0°C charging	Temperature	Action
	No	< 0°C	Stop charging
		> 3°C	Resume charging
	Yes	- 20°C ~ 0°C	Reduce charging current
		> 3°C	Resume normal charging

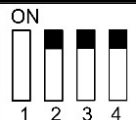
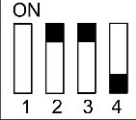

Battery selection

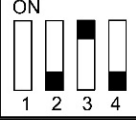
The battery type for the target battery can be selected using DIP switches 2, 3 and 4. This setting will determine the charging parameters used for charging the target battery, such as charging voltage and temperature compensation.

Before you connect and use the charger, please set the correct battery type for the target battery from the range of 8 options below.

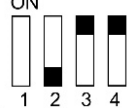
DIP switches		Battery type	Boost voltage (12V / 24V)
 <p>ON 1 2 3 4</p>	<p>2: ON 3: ON 4: ON</p>	GEL	14.3V / 28.6V
 <p>ON 1 2 3 4</p>	<p>2: ON 3: ON 4: OFF</p>	Sealed	14.4V / 28.8V
 <p>ON 1 2 3 4</p>	<p>2: ON 3: OFF 4: ON</p>	Flooded / AGM	14.7V / 29.4V
 <p>ON 1 2 3 4</p>	<p>2: OFF 3: ON 4: OFF</p>	LiFePO4	13.9V / 27.8V
 <p>ON 1 2 3 4</p>	<p>2: OFF 3: OFF 4: ON</p>	LiFePO4	14.2V / 28.4V
 <p>ON 1 2 3 4</p>	<p>2: ON 3: OFF 4: OFF</p>	LiFePO4	14.4V / 28.8V
 <p>ON 1 2 3 4</p>	<p>2: OFF 3: OFF 4: OFF</p>	LiFePO4	14.6V / 29.2V
 <p>ON 1 2 3 4</p>	<p>2: OFF 3: ON 4: ON</p>	Lithium-ion (NCM)	12.6V / 25.2V

Note: the battery type should not be changed whilst the charger is powered. If the battery type needs to be changed, first power off the charger, then change the DIP switch configuration, then turn the charger on again.

Note: any lithium battery used with this charger must have a Battery Management System (BMS). Charging of lithium batteries without BMS is not permitted.

LED lights

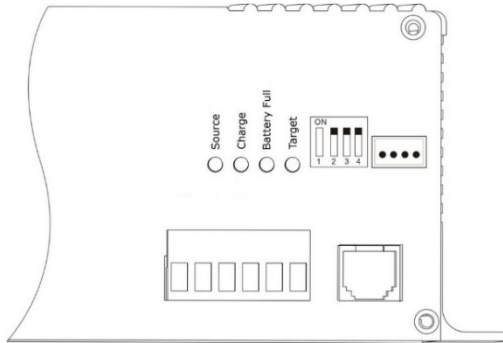

Name	Colour	LED status	Details
Source	Green	OFF	No D+ signal, no charging
		Slow flashing (1 flash / 5 seconds)	Source battery voltage is < 11.0V. If the source battery voltage reduces further to < 10.8V, the charging will stop. It resumes when the voltage returns to 12.5V.
		Fast flashing (1 flash / 1 second)	Source battery voltage > 16V
		ON	Source battery voltage is normal
Charge	Yellow	OFF	No charging
		Slow flashing (1 flash / 2 seconds)	Lithium battery does not charge below 0°C
		Fast flashing (1 flash / 1 second)	Charger is overheated
		Extended flashing (4 seconds ON and 1 second OFF)	Reduced current charging (battery temperature > 50°C or < -20°C)
		ON	Charging
Battery full	Green	OFF	No charging
		Slow flashing (1 flash / 5 seconds)	Boost (constant current) charging stage
		Fast flashing (1 flash / 1 second)	Absorption (constant voltage) charging stage
		ON	Battery full
Target	Red	Slow flashing (1 flash / 5 seconds)	Target battery voltage is normal
		Fast flashing (1 flash / 1 second)	Target battery over-voltage, high voltage disconnect (HVD)
		ON	Target battery low-voltage, low voltage disconnect (LVD)

Note: the above data is for 12V batteries. For a 24V battery, multiply voltage values by 2.

Charging process

Boost (constant current) charging stage: during this stage, the charger will charge the target battery with the maximum rated current until the target battery voltage reaches the boost voltage.

Absorption (constant voltage) charging stage: when the target battery voltage reaches the boost voltage, the charger will enter the absorption (constant voltage) charging stage. During this stage the charger will maintain the boost voltage and the charging current will gradually reduce. This stage will last for 1 or 2 hours depending on the battery type.

Float charging stage: after the absorption stage, the charger will reduce the charging voltage to the float voltage and continue charging the target battery with a low current to maintain it at this level.

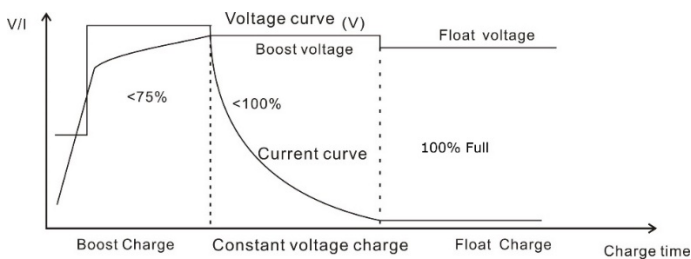

Equalisation: for selected battery types, the charger will perform equalisation charging by timer once a month with a higher charging voltage, in order to bring all battery cells to the same level. Equalisation charging will last for 2 hours. Please refer to the battery types table for more information.

Note: if the target battery voltage is $> 12.6V$ ($> 25.2V$ for 24V battery) at the start of the charging process, the charger will not perform the absorption (constant voltage) stage and will instead charge to the boost voltage level and then go straight to the float charging stage.

Protection functions

Protection	Description
Target battery overvoltage	If the target battery voltage is $>$ High Voltage Disconnect (HVD) voltage, the charging will stop. If the target battery voltage is $>$ boost voltage value + 0.2V for 10 seconds, the charging will stop. Buzzer alarm: beeps once repeatedly for 1 minute
Target battery low voltage	If the target battery voltage is $<$ Low Voltage Disconnect (LVD) voltage, the charging will stop. Buzzer alarm: beeps twice repeatedly for 1 minute.
Source battery low voltage	If the source battery voltage is between 10.8V - 12.3V (12V) / 21.6V - 24.6V (24V), the charging current is reduced.

	If the source battery voltage is < 10.8V (12V) / 21.6V (24V), the charging stops.
Overpower	The maximum charging current and the maximum charging power is limited to the rating of the charger.
Battery reverse polarity	If the target or the source battery is connected with a reverse polarity, it will blow the fuse inside the charger and may also cause hardware damage to the charger. Please contact the supplier of the charger with all the details, including which battery was connected with a reversed polarity.
Overheating (internal temperature)	If the internal temperature is > 85°C, the charging will stop. Charging will resume once the temperature drops to 60°C. If the internal temperature is > 75°C but < 85°C, the charging current will be reduced. Charging at full current will resume once the temperature drops to 60°C. Buzzer alarm: two consecutive beeps followed by a single beep for 1 minute.
System voltage error	If the battery voltage in a 12V system is > 16V / or in a 24V system > 32V, the charging will not start. Buzzer alarm sound: <ul style="list-style-type: none"> • 12V to 12V models: beeps once repeatedly for 1 minute • Models with 24V batteries: beeps 4 times repeatedly for 1 minute

Battery type parameters

Battery type	Boost	Float	Equalisation	High Voltage Disconnect (HVD)	Low Voltage Disconnect (LVD)	Constant voltage charging time
GEL	14.3V	13.8V	-	15.5V	11V	2h
Sealed	14.4V	13.5V	14.6V	15.5V	11V	2h
Flooded / AGM	14.7V	13.5V	14.8V	15.5V	11V	2h
LiFePO4 (13.9V)	13.9V	13.8V	-	15.5V	11V	1h
LiFePO4 (14.2V)	14.2V	13.8V	-	15.5V	11V	1h
LiFePO4 (14.4V)	14.4V	13.8V	-	15.5V	11V	1h
LiFePO4 (14.6V)	14.6V	13.8V	-	15.5V	11V	1h
Lithium-ion (NCM)	12.6V	12.5V	-	13.5V	9.3V	1h

Note: The above data is for 12V batteries. If the voltage of your battery is 24V, multiply all voltage parameters by 2.

Specifications

Model	DC1212-30	DC1212-60	DC1224-25	DC2424-50	DC2412-60
Target battery					
Gel, Sealed, AGM rated voltage	12V		24V		12V
LiFePO4 rated voltage	12.8V		25.6V		12.8V
Lithium-ion (NCM) rated voltage	11.1V		22.2V		11.1V
Recommended battery capacity	45-280 Ah	100-520 Ah	45-280 Ah	100-520 Ah	100-520 Ah
Battery operating voltage range	8-16V		16-32V		8-16V
Source battery					
Rated battery voltage	12V			24V	
Recommended min. battery capacity	60Ah	80-100Ah	60Ah	80-100Ah	80-100Ah
Battery operating voltage range	10.5-16V			21-32V	
General parameters					
Maximum charging power	390W	780W	650W	1300W	780W
Maximum charging current	30A	60A	25A	50A	60A
Effective D+ signal voltage range	8-16V			16-32V	
Temperature compensation	-3mV/°C/2V				
"TR" signal	12V / 1A		-		
Target battery temperature sensor input "T T"	Yes				
Target battery voltage input "Ss-, Ss+"	Yes				
Stand-by current	17±2 mA		12±2 mA		28±2 mA
Weight	1.44kg	1.6kg			
Operating temperature	From -20°C to 50°C				
Dimensions	190x194x70 mm	190x215x70 mm			

CB and CBR circuit breakers (optional)

Optional surface mounted (CB series) and recess mounted (CBR series) DC circuit breakers can be purchased from Photonic Universe and used instead of fuses when connecting this charger to the source and target batteries. The range of circuit breakers includes 30A, 40A, 50A, 60A and 80A circuit breakers rated for 12V / 24V systems with product codes **CB30 – CB80**, **CBR40**, **CBR80**.



Temperature sensor DCDC-TS (optional)

This charger is compatible with an optional temperature sensor **DCDC-TS**. The sensor will measure the external temperature of the target battery and provide the real time temperature readings to the charger for voltage adjustment and protection (please see the section about “T T” terminals for reference). The voltage adjustment applied for lead acid batteries is 18 mV/°C for 12V batteries and 36 mV/°C for 24V batteries. If the temperature sensor is not connected, the charger will charge the target battery based on the default temperature settings for 25°C.



Remote meter ACDC-RM (optional)

An optional remote LCD meter **ACDC-RM** can be connected to the charger to display charging parameters such as real time battery voltage, charging current, charging Ah, charging Wh and any fault information.



Bluetooth dongle ACDC-BT (optional)

Using an optional Bluetooth dongle **ACDC-BT**, the charger can be connected to a mobile phone app to allow the user to monitor charging parameters such as real time battery voltage, charging current, charging Ah, charging Wh and any fault information.



To setup the Bluetooth dongle and connection to the mobile phone, please install the correct and up-to-date version of the app using the name, links or QR codes for the app provided in a separate user manual for the Bluetooth dongle.

If you would like to purchase any of these optional extras, please visit our online shop

www.PhotonicUniverse.com

or call 0203 150 1111 (international +44 203 150 1111) for a phone order.

Photonic Universe Ltd

E-mail: info@photonicuniverse.com

Web: www.photonicuniverse.com

Tel.: +44 (0) 203 150 11 11

Fax: +44 (0) 203 150 12 12